

## ENGINE

Model	Case F5C, Tier 4 Interim Emissions Certified
Type	Diesel 4-stroke, turbocharged
Cylinders	4
Bore/Stroke	3.90 x 4.33 in (99 x 110 mm)
Displacement	207 in <sup>3</sup> (3.4 L)
Fuel injection	Direct, high pressure common rail – HPCR
Fuel	Diesel
Fuel filter	w/ water trap
Air intake	Cross-flow
Cooling	Liquid
Engine speeds*	RPM
Rated speed – full load	2200
Low idle	875 – 1025
High idle – no load	2300 – 2450
Horsepower @ 2200 RPM:	
Gross	85 hp (63 kW)
Net w/ viscous fan**	83 hp (62 kW)
Net	78 hp (59 kW)
Maximum torque @ 1400 RPM:	
Gross	276 lb-ft (374 N-m)
Net w/ viscous fan	274 lb-ft (372 N-m)
Net	268 lb-ft (364 N-m)
Torque rise at rated speed	36%
Radiator:	
Core type	Square wave
Core size area	486 in <sup>2</sup> (3145 cm <sup>2</sup> )
Rows of tubes	4
39 degree fan:	
Style	7 blade suction
Diameter	19.65 in (499 mm)
Ratio	1.1:1
Water pump style	Integral
Engine oil pump:	
Deep sump plate cooler w/ pressurized under-piston nozzles	
Pump operating angle ratings:	
Side to side	Rated 35°
Fore and aft	Rated 35°
Oil filtration	Replaceable, full flow spin on

NOTE: \*Meets federal emission regulations.

\*\*Viscous fan included w/ Cab  
Convenience package.

## POWERTRAIN

Transmission – standard:		
4F-4R Power Shuttle Synchronesh		
Transmission manual gear shift, fully synchronized		
Transmission – optional:		
Powershift S-Type, 4F-3R fully synchronized		
Specifications below apply to both Power Shuttle and Powershift S-Type transmission unless otherwise indicated.		
Gear ratios	Forward/Reverse	
1st	5.603/4.643	
2nd	3.481/2.884	
3rd	1.584/1.313	
4th	0.793/0.657*	
Travel speeds	Forward	Reverse
	mph (kph)	mph (kph)
1st	3.8 (6.1)	4.5 (7.3)
2nd	6.1 (9.8)	7.3 (11.7)
3rd	12.9 (20.8)	15.5 (24.9)
4th	24.3 (39.1)	29.1 (46.9)*
NOTE: Travel speeds at 2293 engine RPM w/ 19.5 L x 24.0 tires. Speeds decrease w/ 17.5 L x 24.0 rear tires. *4R not available on Powershift S-Type.		
Torque converter ratio	3.2	
Differential lock	On-the-go push-button activation	
Front 4WD/Rear axle:		
Differential ratio	2.0/2.5	
Planetary hub ratio	6.0/6.4	
Total reduction ratio	12.0/16.0	
Service brakes:		
Individually applied, power assisted, hydraulically actuated, maintenance-free, self-adjusting, outboard mounted, wet disc, 2 per side.		
Disc area	384 in <sup>2</sup> (0.25 m <sup>2</sup> )	
Parking brakes	Trans Mounted spring-applied hydraulic release – SAHR	

## ELECTRICAL

Voltage	12 Volts, negative ground
Alternator	120 amp
Battery	850 cold-cranking amps
Opt. batteries (2)	850 cold-cranking amps
Power plugs (2)	30 amps total

## OPERATOR ENVIRONMENT

ROPS/FOPS certified protective canopy; Anti-vandalism cover for dash – w/ canopy only; Rear fenders extensions; Coat hook w/ garment strap; Interior rearview mirror, convex 3.54 in (90 mm) wide x 10.83 in (275 mm) high; Non-suspension seat – 180° swivel – Vinyl; 2 in (50 mm) retractable seat belt; Cup holder/ storage tray mounted on left-hand fender; Right-hand storage compartment w/ lid.	
Gauges:	Engine water temperature; Converter oil temperature; Fuel level; Tachometer/ hourmeter; Voltmeter.
Warning lights:	Air cleaner restriction; Alternator; A/C high pressure; Cold start; Engine oil pressure low; Hydraulic oil filter bypass; Parking brake engagement; Low fuel.
Audible alarms:	Coolant temperature; Engine oil pressure; Parking brake engagement; Shuttle engagement/seat position; Backup.
Horn	dual switched front and rear

## OPERATING WEIGHT

### Configuration 1 – SAE Transport:

82 in (2.08 m) LL bucket, 2WD, 17.5 L x 24.0 rear tires, standard dipper, 24 in (610 mm) Trenching bucket, standard cast stabilizer pads, ROPS canopy, vinyl-suspension seat, dual battery, no operator, fully fueled:	14,564 lb (6607 kg)
--	---------------------

### Configuration 2 – SAE Transport:

82 in (2.08 m) bucket, 4WD, 19.5 L x 24.0 rear tires, Extendahoe®, 24 in (0.61 m) HD bucket, flip stabilizer pads, 1,100 lb (500 kg) counterweight, ROPS cab, cloth, air-suspension seat, dual battery, no operator, mechanical backhoe quick coupler and 40 gal (151 L) plastic fuel tank:	17,454 lb (7917 kg)
---	---------------------

### Add-on weights:

Cab – over canopy	0 lb (0 kg)
Fabricated stabilizer pads	141 lb (64 kg)
Counterweights	700 lb (318 kg)
Extendahoe®	285 lb (129 kg)
4WD w/ driveshaft guard	283 lb (128 kg)
Buckets:	
82 in (2.08 m) 4 IN 1®	1,451 lb (658.0 kg)
82 in (2.08 m) Long Lip	683 lb (310.0 kg)
93 in (2.36 m) Long Lip	1,188 lb (539.0 kg)
24 in (0.61 m) Heavy-Duty Universal:	427 lb (193.5 kg)

## HYDRAULICS

<b>Pump:</b>	Parker P330 Single Section Gear Pump
<b>Standard main relief pressure:</b>	3,350 +/- 50 psi @ 28.5 gpm (231 +/- 3.5 bar @ 108 L/min)
<b>Filtration:</b>	7 micron, return line, full flow, spin on element, condition indicator light for filter.
<b>Oil cooler</b>	Heavy-duty
<b>Loader flow @ rated engine RPM:</b>	28.5 gpm @ 3,000 psi (108 L/min @ 207 bar)
<b>Loader control valve:</b>	Two- or three-spool open center monoblock valve. Two- and three-spool valves have a single lever manual control for lift and tilt functions. Three-spool valve uses a proportional Electro-Hydraulic control for the auxiliary function. The lift lever has a positive hold "Float" position and a "return-to-dig" feature. System Main Relief valve is single stage w/ Manual Backhoe Controls, dual stage relief valve w/ Pilot Backhoe Controls.
<b>Loader auxiliary hydraulics proportional thumb switch w/ detent on loader control handle.</b>	
<b>Loader auxiliary hydraulics w/ full available flow:</b>	0 – 28.5 gpm (0 – 108 L/min)
<b>Backhoe flow @ rated engine RPM:</b>	28.5 gpm @ 3,000 psi (108 L/min @ 207 bar)
<b>Manual backhoe control valve:</b>	Six- or seven-spool monoblock open center control valve. Features "Pro-Control" which includes custom designed spools for each individual function along w/ "swing cushioning" valve for zero-wag swing control. Basic control valve has an open center parallel circuit for all functions.
<b>Pilot backhoe control valve:</b>	Six-, seven- or eight-spool sectional closed center control valve. Features "Pro-Control" which includes custom designed spools for each individual function along w/ "swing cushioning" valve for zero-wag swing control. Basic control valve is closed center, w/ circuits in parallel w/ a post-compensated, flow sharing feature for simultaneous operation of all circuits.
<b>Unidirectional Auxiliary Hydraulics:</b>	
<b>Unidirectional hydraulic valve is equipped w/ an adjustable LS relief valve to control attachment pressure and a 6 position flow control selector for 6 detented, distinct flow settings.</b>	
<b>Actuation:</b>	Manual backhoe controls – cab floor pedal Pilot controls – left-hand joystick

## SERVICE CAPACITY

<b>Fuel tank</b>	42.0 gal (159 L)
<b>Hydraulic system:</b>	
Total	112 qt (106.0 L)
w/ Extendahoe®	118 qt (111.7 L)
Reservoir w/ filter	58 qt (55.0 L)
Reservoir w/o filter	56 qt (53.0 L)
<b>Transmission – total system:</b>	
2WD Standard	18 qt (17.0 L)
2WD Powershift	23 qt (21.7 L)
4WD Standard	21 qt (19.4 L)
4WD Powershift	22 qt (20.7 L)
<b>4WD Front axle:</b>	
Differential	8.1 qt (7.7 L)
Planetarys – each	0.5 qt (0.5 L)
<b>Rear axle:</b>	
Differential and planetarys	14.4 qt (13.6 L)
<b>Engine oil w/ filter</b>	14.4 qt (13.6 L)
<b>Cooling system:</b>	
w/ heater	17.8 qt (16.8 L)
w/o heater	17.0 qt (16.1 L)
<b>Window washer reservoir</b>	3.0 qt (2.8 L)

## OTHER SPECIFICATIONS

<b>Front tires:</b>	
2WD	11.0 L x 16.0, 10-ply rating
4WD	12.0 L x 16.5, 8-ply rating
<b>Rear tires:</b>	
2/4WD	19.5 L x 24.0, 10-ply rating
2/4WD	17.5 L x 24.0, 10-ply rating
2/4WD	16.9 L x 28.0, 10-ply rating
<b>Loader:</b>	
Bucket position indicator; Lifting lugs on standard bucket; Single lever control w/ self-leveling and return-to-dig; Hand operated clutch disconnects on loader and shift levers, single lever 4-function loader control: lift, dump, clutch cut-out, differential lock.	

### Loader bucket sizes:

Width	Weight	Struck	Heaped
<b>Long Lip Bucket w/o bolt-on edge</b>			
82 in (2.08 m)	683 lb (310 kg)	0.87 yd <sup>3</sup> (0.67 m <sup>3</sup> )	1.03 yd <sup>3</sup> (0.79 m <sup>3</sup> )
93 in (2.36 m)	1,188 lb* (539 kg)	1.07 yd <sup>3</sup> (0.82 m <sup>3</sup> )	1.25 yd <sup>3</sup> (0.96 m <sup>3</sup> )
<b>4 IN 1® Bucket w/ bolt-on edge</b>			
82 in (2.08 m)	1,451 lb* (658 kg)	0.85 yd <sup>3</sup> (0.65 m <sup>3</sup> )	1.04 yd <sup>3</sup> (0.80 m <sup>3</sup> )

NOTE: \*Weight of 4 IN 1® bucket includes edges, cylinders and tube lines.

## OTHER SPECIFICATIONS (cont.)

### Turning diameter\*:

<b>2WD:</b>	
Brakes on	10 ft 8 in (3.24 m)
Brakes off	12 ft 4 in (3.79 m)
<b>4WD – engaged:</b>	
Brakes on	11 ft 4 in (3.45 m)
Brakes off	13 ft 10 in (4.21 m)
<b>4WD – disengaged:</b>	
Brakes on	11 ft 0 in (3.36 m)
Brakes off	12 ft 3 in (3.72 m)

### Backhoe:

Over center design, fabricated "S" boom; Open-center hydraulics – pro control system; 15,700 lb-ft (21 297 N-m) swing torque; 198° bucket rotation; Foot-swing w/ 3-lever control; Wing stabilizers w/ cleated dirt pad.

### Backhoe bucket sizes:

Width	Weight	Heaped
<b>General Purpose Trenching Buckets</b>		
18 in (457 mm)	231.5 lb (105.0 kg)	4.70 ft <sup>3</sup> (0.13 m <sup>3</sup> )
24 in (610 mm)	272.0 lb (123.4 kg)	6.26 ft <sup>3</sup> (0.18 m <sup>3</sup> )
<b>Universal Buckets</b>		
12 in (305 mm)	294.5 lb (133.6 kg)	3.40 ft <sup>3</sup> (0.10 m <sup>3</sup> )
18 in (457 mm)	356.3 lb (161.6 kg)	5.30 ft <sup>3</sup> (0.15 m <sup>3</sup> )
24 in (610 mm)	426.6 lb (193.5 kg)	7.70 ft <sup>3</sup> (0.22 m <sup>3</sup> )
30 in (762 mm)	489.4 lb (222.0 kg)	10.20 ft <sup>3</sup> (0.29 m <sup>3</sup> )
36 in (914 mm)	552.3 lb (250.5 kg)	12.70 ft <sup>3</sup> (0.36 m <sup>3</sup> )
<b>High Capacity Buckets</b>		
24 in (610 mm)	446.7 lb (202.6 kg)	8.50 ft <sup>3</sup> (0.24 m <sup>3</sup> )

NOTE: \*Turning diameter dimensions curb to curb w/ 17.5 L x 24.0 rear tires and 4 IN 1® bucket.

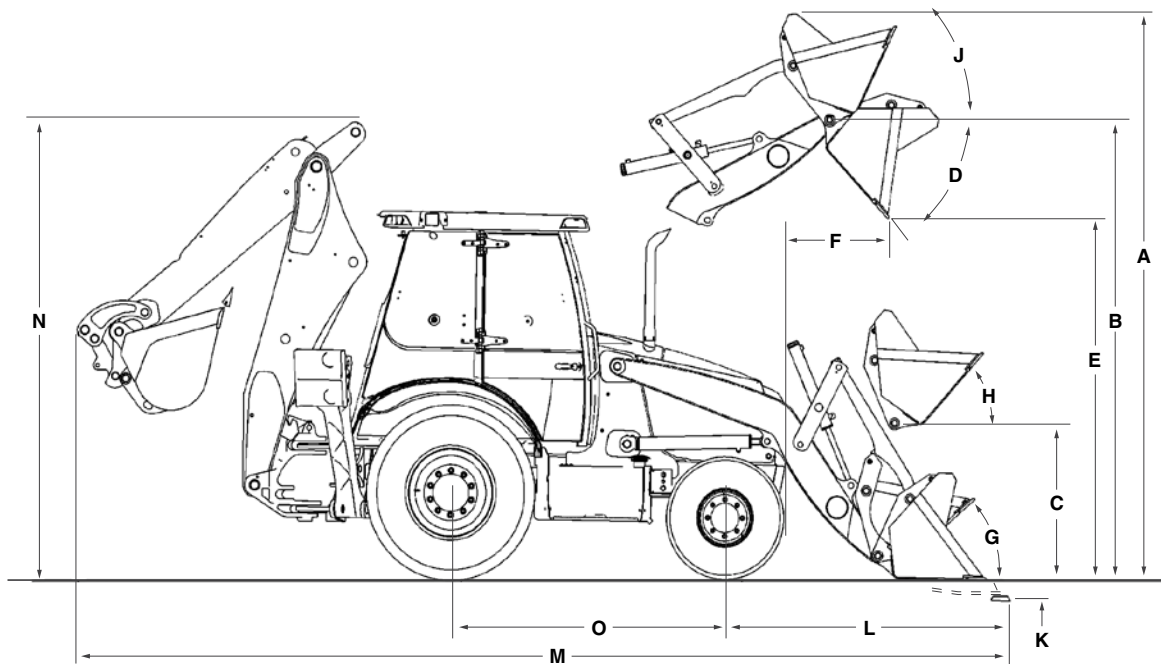

Line drawings are for illustrative purpose only and may not be exact representation of unit.

## LOADER DIMENSIONS\*

	Long Lip Bucket	4 IN 1® Bucket
<b>A.</b> Overall operating height – fully raised	13 ft 9 in (4.18 m)	13 ft 8 in (4.16 m)
Height to:		
<b>B.</b> Bucket hinge pin fully raised	11 ft 3 in (3.42 m)	11 ft 3 in (3.42 m)
<b>C.</b> Bucket hinge pin at SAE carry	13.6 in (345 mm)	13.6 in (345 mm)
<b>D.</b> Dump angle at full height	47°	47°
<b>E.</b> Dump clearance at full height, 45° dump:		
Bucket	8 ft 10 in (2.69 m)	8 ft 11 in (2.71 m)
Clam open	—	9 ft 8 in (2.96 m)
<b>F.</b> Dump reach at full height, 45° dump:		
Bucket	31.5 in (801 mm)	29.1 in (738 mm)
Clam open	—	15.3 in (388 mm)
Bucket rollback:		
<b>G.</b> @ Groundline	42°	42°
<b>H.</b> @ SAE carry	42°	42°
<b>J.</b> @ Full height	Adjustable	Adjustable
<b>K.</b> Digging depth below grade:		
Bucket flat	6.1 in (155 mm)	4.8 in (122 mm)
Clam open – dozing	—	4.1 in (103 mm)
<b>L.</b> Reach from front axle centerline – bucket on ground	6 ft 1 in (2.08 m)	6 ft 1 in (2.03 m)
Lift capacity to full height	6,803 lb (3086 kg)	6,454 lb (2930 kg)
Breakout force:		
Lift cylinders	9,506 lb (4228 daN)	9,276 lb (4126 daN)
Dump cylinders	10,622 lb (4724 daN)	11,312 lb (5032 daN)
Bucket cutting edge width	82.5 in (2.09 m)	82.0 in (2.08 m)
Maximum grading angle	114°	114°
Maximum clam opening	—	38.3 in (972 mm)
Moldboard height	—	36.8 in (934 mm)
Raising time to full height	4.6 sec	4.6 sec
Bucket dumping time	1.1 sec	1.1 sec
Lowering time:		
Power down	2.6 sec	2.6 sec
Return-to-dig	3.6 sec	3.6 sec
Clam:		
Open time	—	1.0 sec
Close time	—	1.0 sec

NOTE: \*Loader dimensions taken with 4WD, 19.5 L x 24.0 rear tires.

## DIMENSIONS

	2WD with 19.5 L x 24.0 tires	4WD with 19.5 L x 24.0 tires
<b>M. Overall transport length:</b>		
Long Lip bucket with Quick Coupler	23 ft 5 in (7.14 m)	23 ft 4 in (7.10 m)
4 IN 1° bucket with Quick Coupler	23 ft 3 in (7.07 m)	23 ft 1 in (7.04 m)
Long Lip bucket with Straight Links	23 ft 6 in (7.15 m)	23 ft 4 in (7.12 m)
4 IN 1° bucket with Straight Links	23 ft 3 in (7.09 m)	23 ft 2 in (7.06 m)
Overall transport width – rear tires	6 ft 10 in (2.07 m)	6 ft 10 in (2.07 m)
Height:		
To top of canopy	8 ft 9 in (2.66 m)	8 ft 9 in (2.66 m)
To top of cab	8 ft 11 in (2.72 m)	8 ft 11 in (2.72 m)
To top of exhaust stack	8 ft 7 in (2.62 m)	8 ft 7 in (2.61 m)
<b>N. Transport</b>	10 ft 10 in (3.30 m)	11 ft 1 in (3.37 m)
Ground clearance at backhoe frame	15.0 in (380 mm)	15.0 in (380 mm)
Angle of departure	15.3°	19.0°
Front wheel tread:		
11.0 L x 16.0	67.5 in (1.71 m)	67.5 in (1.71 m)
12.0 L x 16.5	67.7 in (1.72 m)	67.7 in (1.72 m)
Rear wheel tread:		
17.5 L x 24.0	63.1 in (1.60 m)	63.1 in (1.60 m)
19.5 L x 24.0	61.2 in (1.55 m)	61.2 in (1.55 m)
Width over tires:		
11.0 L x 16.0	79.3 in (2.01 m)	79.3 in (2.01 m)
12.0 L x 16.5	81.1 in (2.06 m)	81.1 in (2.06 m)
17.5 L x 24.0	81.7 in (2.07 m)	81.7 in (2.07 m)
19.5 L x 24.0	81.4 in (2.07 m)	81.4 in (2.07 m)
<b>O. Wheelbase</b>	84.0 in (2.13 m)	84.5 in (2.15 m)

## CYLINDERS

	Bore Diameter	Rod Diameter	Stroke	Closed Length
<b>Loader:</b>				
Lift (2)	3.25 in (82.6 mm)	1.75 in (44.5 mm)	28.86 in (733.0 mm)	41.81 in (1062.0 mm)
Dump (2)	3.00 in (76.2 mm)	1.50 in (38.1 mm)	20.33 in (516.5 mm)	30.31 in (769.9 mm)
4 IN 1° clam (2)	3.00 in (76.2 mm)	1.75 in (44.5 mm)	9.08 in (230.6 mm)	19.62 in (498.3 mm)
<b>Backhoe:</b>				
Boom	4.50 in (114.3 mm)	2.25 in (57.2 mm)	38.22 in (971.5 mm)	52.82 in (1341.6 mm)
Dipperstick	4.25 in (108.0 mm)	2.25 in (57.2 mm)	25.14 in (628.5 mm)	39.65 in (1007.0 mm)
Bucket	3.25 in (82.6 mm)	2.25 in (57.2 mm)	35.35 in (897.9 mm)	48.17 in (1223.6 mm)
Extendahoe®	3.00 in (76.2 mm)	1.75 in (44.5 mm)	42.05 in (1068.0 mm)	56.22 in (1428.0 mm)
Swing (2)	3.75 in (95.3 mm)	2.00 in (50.8 mm)	11.50 in (292.0 mm)	24.44 in (620.8 mm)
Stabilizer (2)	4.25 in (108.0 mm)	2.25 in (57.2 mm)	21.37 in (542.9 mm)	33.87 in (860.2 mm)

## AXLE RATINGS

	Front – 2WD	Rear	Front – 4WD
Maximum static	70,821 lb (32 124 kg)	90,145 lb (40 889 kg)	64,613 lb (29 308 kg)
Dynamic operating	44,261 lb (20 076 kg)	56,200 lb (25 492 kg)	39,328 lb (17 839 kg)
Static operating	17,704 lb (8030 kg)	22,480 lb (10 197 kg)	15,732 lb (7136 kg)
Oscillation – front axle	22° total – 11% side to side	–	22° total – 11% side to side

## BACKHOE LIFT CAPACITIES

	Standard Backhoe	Extendahoe®	
		Retracted	Extended
<b>Boom Lift</b>	Lift Capacity lb (kg)	Lift Capacity lb (kg)	Lift Capacity lb (kg)
+16 ft (4.87 m)	—	—	1,693 (768)
+14 ft (4.27 m)	2,472 (1121)	2,271 (1030)	1,979 (897)
+12 ft (3.66 m)	2,857 (1296)	2,644 (1199)	2,124 (964)
+10 ft (3.05 m)	2,966 (1345)	2,748 (1246)	2,172 (985)
+8 ft (2.44 m)	2,983 (1353)	2,761 (1252)	2,169 (984)
+6 ft (1.83 m)	2,963 (1344)	2,739 (1242)	2,173 (985)
+4 ft (1.22 m)	2,929 (1329)	2,701 (1225)	2,165 (982)
+2 ft (0.61 m)	2,892 (1312)	2,662 (1207)	2,153 (977)
<b>Ground Level</b>	2,858 (1297)	2,625 (1191)	2,153 (977)
-2 ft (0.61 m)	2,834 (1285)	2,598 (1178)	2,145 (973)
-4 ft (1.22 m)	2,827 (1282)	2,588 (1174)	2,143 (972)
-6 ft (1.83 m)	2,853 (1294)	2,609 (1183)	2,154 (977)
-8 ft (2.44 m)	2,949 (1338)	2,698 (1224)	2,189 (993)
-10 ft (3.05 m)	3,319 (1506)	3,053 (1385)	2,270 (1030)
-12 ft (3.66 m)	—	—	2,429 (1102)
-14 ft (4.27 m)	—	—	3,115 (1413)
<b>Dipper Lift:</b>			
+14 ft (4.27 m)	—	—	3,154 (1431)
+12 ft (3.66 m)	4,343 (1970)	4,139 (1877)	2,981 (1352)
+10 ft (3.05 m)	4,027 (1827)	3,826 (1735)	2,823 (1281)
+8 ft (2.44 m)	4,112 (1865)	3,910 (1774)	2,855 (1295)
+6 ft (1.83 m)	4,563 (2070)	4,357 (1976)	3,010 (1365)
+4 ft (1.22 m)	5,398 (2449)	5,177 (2348)	2,948 (1337)
+2 ft (0.61 m)	—	—	3,486 (1581)

## BACKHOE OPERATIONAL DATA

	Standard Backhoe	Extendahoe®	
		Retracted	Extended
<b>Digging depth:</b>			
Maximum	14 ft 10 in (4.50 m)	14 ft 9 in (4.50 m)	18 ft 3 in (5.55 m)
2 ft (610 mm) flat bottom	14 ft 8 in (4.46 m)	14 ft 8 in (4.46 m)	18 ft 1 in (5.52 m)
8 ft (2.44 m) flat bottom	13 ft 8 in (4.16 m)	13 ft 8 in (4.16 m)	17 ft 4 in (5.29 m)
<b>Overall reach from:</b>			
Rear axle centerline	21 ft 11 in (6.68 m)	21 ft 11 in (6.68 m)	25 ft 4 in (7.72 m)
Swing pivot	18 ft 4 in (5.57 m)	18 ft 4 in (5.57 m)	21 ft 8 in (6.60 m)
<b>Loading height</b>	11 ft 9 in (3.59 m)	11 ft 9 in (3.59 m)	14 ft 1 in (4.30 m)
<b>Loading reach – dipper retracted</b>	6 ft 9 in (2.04 m)	6 ft 9 in (2.04 m)	9 ft 4 in (2.84 m)
<b>Swing arc</b>	180°	180°	180°
<b>Bucket rotation:</b>			
Straight links	175.6°	175.6°	175.6°
Mechanical coupler	198.0°	198.0°	198.0°
<b>Stabilizer spread – centers</b>			
Flip pad	9 ft 5 in (2.87 m)	9 ft 5 in (2.87 m)	9 ft 5 in (2.87 m)
Cast Pad	9 ft 9 in (2.97 m)	9 ft 9 in (2.97 m)	9 ft 9 in (2.97 m)
<b>Digging force:</b>			
Bucket cylinder	11,334 lb (50 414 N)	11,334 lb (50 414 N)	11,334 lb (50 414 N)
Dipper cylinder	6,710 lb (29 484 N)	6,710 lb (29 484 N)	4,887 lb (21 738 N)
<b>Leveling angle:</b>			
Flip pad	12.8°	12.8°	12.8°
Cast pad	13.8°	13.8°	13.8°

## STANDARD EQUIPMENT

### OPERATOR ENVIRONMENT

See page 1

### ENGINE

Case F5C diesel  
Cooled EGR  
Diesel Particulate Filter  
Full flow engine oil filter  
Air cleaner – replaceable dry type with radial seal  
Aspirated air cleaner  
Muffler, non spark arresting  
Radiator with de-aeration bottle  
Antifreeze to -34° F (-37° C)  
Throttles, both hand and foot  
Self adjusting belt tensioner  
Glow plugs cold start  
In line fuel strainer

### POWERTRAIN

Front axle, as selected:  
2WD heavy-duty front axle with 11.0 L x 16.0 tires  
4WD heavy-duty mechanically driven front axle with 12.0 L x 16.5 tires and drive shaft guard  
Rear axle:  
2/4WD heavy-duty outboard planetary drive with 17.5 L x 24.0 tires  
4F-4R Power Shuttle Synchromesh transmission  
Torque converter – 11.8 in (300 mm)  
On-the-go electric 4WD control  
Electric F/R shuttle control  
Electric differential lock control, push-button activation on the loader control lever  
Park brake, spring-applied, hydraulic release – SAHR

### HYDRAULICS

Pump 28.5 gal/min @ 3,000 lb/in<sup>2</sup> (107.9 L/min @ 207 bar)  
Heavy-duty hydraulic oil cooler  
7 micron, spin on oil filter

### LOADER

See page 2

### BACKHOE

See page 2

### OTHER

Forward tilt engine hood  
Replaceable, molded front bumpers  
Front/Rear tie downs  
Reflective logos  
Lights – cab and canopy:  
2 rear tail/stop  
2 front flashers/turn  
2 rear flashers/turn  
Lights – cab only:  
2 front driving lights – 55 W  
Adjustable halogen work lights – 55 W:  
2 front  
2 side – left and right  
4 rear  
Lights – canopy only:  
2 front driving lights – 55 W  
Adjustable halogen work lights – 55 W:  
2 side – left and right  
2 rear

## OPTIONAL EQUIPMENT

### OPERATOR ENVIRONMENT

Auto Ride Control – 4WD models  
Standard Ride Control – 2WD models  
Comfort Steer with momentary latching switch, two-speed steering pump and 3rd/4th gear cutout  
ROPS/FOPS certified protective cab with rear wipers and floor mat  
Cab Convenience Package containing pull-down sun visor, window washer – front and rear, left-hand storage tray, deluxe interior package, tilt steering column, Sound Reduction Package for cab models – levels reduced to 72 dB (A), right-hand threshold storage box, viscous fan  
Air-conditioning for cab models  
Mechanical suspension seat with flip-up armrests, 180° swivel, cloth or vinyl, adjustable seat and weight, backrest angle, lumbar and cushion angle  
Air Ride suspension seat with flip-up armrests, 180° swivel  
Electric height adjustment, adjustable backrest and lumbar support – cab units cloth, canopy units vinyl  
Pull-down sun visor for canopy models  
Radio, AM/FM Stereo/WB, MP3 auxiliary input – cab models  
3 in (75 mm) seat belt for mechanical and air-suspension seat

### ENGINE

Cold Weather Starting Aid with dual 12 Volt batteries  
Block heater

### POWERTRAIN

Powershift S-Type transmission, 4F-3R fully synchronized, electronic transmission controller and kick down in loader control lever – 2WD or 4WD  
Heavy-duty outboard planetary drive without 19.5 L x 24.0 tires

### HYDRAULICS

Auxiliary backhoe unidirectional hydraulics  
Auxiliary backhoe bidirectional hydraulics: Hand lever operated for manual controls  
Button operated for pilot controls

### LOADER

Auxiliary hydraulics for loader-mounted equipment with thumb-operated proportional control  
Hydraulic front quick coupler  
Bolt-on cutting edges  
Loader linkage without loader bucket  
Tool portfolio of additional attachments  
Buckets – see page 2

### BACKHOE

Auxiliary hydraulics with flow from 0 to 36 gal/min (0 to 136 L/min)  
Extendahoe®  
Two-lever controls – backhoe or Extendahoe®  
Pilot operated control system  
Fingertip proportional Electro-Hydraulic stabilizer controls  
Thumb-operated proportional Electro-Hydraulic Extendahoe® control  
Thumb-operated horn button  
Thumb-operated auxiliary hydraulic control  
Infinitely adjustable towers  
In-cab switchable “excavator to backhoe” control pattern change  
Flip over stabilizer pads  
Cemetery/Street pads  
Case mechanical quick coupler  
Bucket retrofit kits  
Buckets – see page 2  
**OTHER**  
11.0 L x 16.0 10-ply, 12.0 L x 16.5 8-ply or 17.5 L x 24.0 10-ply front tires  
19.5 L x 24.0 10-ply rear tires  
Rotating beacon  
Special paint  
Canopy lights – Additional 2 front and 2 rear halogen lights (55 W)  
Tool box – bolt-on, step-mounted  
Lift hooks – export  
Front counterweights:  
700 lb and 1,100 lb (318 kg and 500 kg)  
Master disconnect switch and remote jump start terminals



NOTE: All specifications are stated in accordance with SAE Standards or Recommended Practices, where applicable.

NOTE: All engines meet current EPA emissions requirements.

IMPORTANT: Case Construction Equipment Inc. reserves the right to change these specifications without notice and without incurring any obligation relating to such change. Case Construction Equipment Inc. does not warrant the safety or reliability of attachments from other manufacturers.

Case is a registered trademark of CNH America LLC. Any trademarks referred to herein, in association with goods and/or services of companies other than CNH America LLC, are the property of those respective companies.

Form No. CCE201305580N  
Replaces form no. CCE201207580N

Printed in U.S.A.  
580N • Page 7 of 7



[www.casece.com](http://www.casece.com)

© 2013 CNH America LLC  
All Rights Reserved



All Case construction equipment is biodiesel ready.